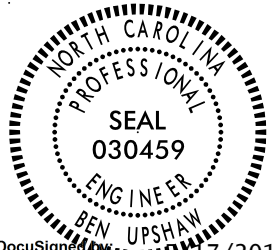

PROJECT REFERENCE NO. W-560IEE	SHEET NO. IA
DIVISION FIVE DESIGN	
	
DocuSigned by: <i>Ben Upshaw</i> 07/17/2017 P.E. CD6EB110D6E54E5	

INDEX OF SHEETS

SHEET NUMBER	SHEET
1	TITLE SHEET
1A	INDEX OF SHEETS, GENERAL NOTES, AND LIST OF STANDARD DRAWINGS
1B	CONVENTIONAL SYMBOLS
1C-1	SURVEY CONTROL SHEETS
2A-1	PAVEMENT SCHEDULE AND TYPICAL SECTIONS
2B-1	SHOULDER WEDGE DETAIL
3B-1	DRAINAGE & EARTHWORK SUMMARY
4 THRU 5	PLAN SHEETS
6	PROFILE SHEET
TMP-1 THRU TMP-2	TRANSPORTATION MANAGEMENT PLANS
PMP-1 THRU PMP-3	PAVEMENT MARKING PLANS
EC-3B THRU EC-5	EROSION CONTROL PLANS
X-1A	CROSS-SECTION SUMMARY SHEET
X-1 THRU X-4	CROSS-SECTIONS

GENERAL NOTES:

2012 SPECIFICATIONS
EFFECTIVE: 01-17-12
REVISED: 07/30/12

GRADING:

THE GRADE LINES SHOWN DENOTE THE FINISHED ELEVATION OF THE PROPOSED OR FUTURE SURFACING AT GRADE POINTS SHOWN ON THE TYPICAL SECTIONS. GRADE LINES MAY BE ADJUSTED AT THEIR BEGINNING AND ENDING AND AT STRUCTURES AS DIRECTED BY THE ENGINEER IN ORDER TO SECURE A PROPER TIE-IN.

CLEARING:

CLEARING ON THIS PROJECT SHALL BE PERFORMED TO THE LIMITS ESTABLISHED BY METHOD II.

SHOULDER CONSTRUCTION:

ASPHALT, EARTH, AND CONCRETE SHOULDER CONSTRUCTION ON THE HIGH SIDE OF SUPERELEVATED CURVES SHALL BE IN ACCORDANCE WITH STD. NO. 560.01

SIDE ROADS:

THE CONTRACTOR WILL BE REQUIRED TO DO ALL NECESSARY WORK TO PROVIDE SUITABLE CONNECTIONS WITH ALL ROADS, STREETS, AND DRIVES ENTERING THIS PROJECT. THIS WORK WILL BE PAID FOR AT THE CONTRACT UNIT PRICE FOR THE PARTICULAR ITEMS INVOLVED.

UTILITIES:

UTILITY OWNERS ON THIS PROJECT ARE DUKE ENERGY, CENTURYLINK, TIME WARNER CABLE AND TOWN OF FUQUAY-VARINA.

ANY RELOCATION OF EXISTING UTILITIES WILL BE ACCOMPLISHED BY OTHERS.

2012 ROADWAY ENGLISH STANDARD DRAWINGS

2012 ROADWAY ENGLISH STANDARD DRAWINGS

The following Roadway Standards as appear in "Roadway Standard Drawings" Highway Design Branch - N. C. Department of Transportation - Raleigh, N. C., Dated January, 2012 are applicable to this project and by reference hereby are considered a part of these plans:

STD.NO.	TITLE
DIVISION 2 - EARTHWORK	
200.02	Method of Clearing - Method II
225.02	Guide for Grading Subgrade - Secondary and Local
DIVISION 3 - PIPE CULVERTS	
300.01	Method of Pipe Installation
310.10	Driveway Pipe Construction
DIVISION 5 - SUBGRADE, BASES AND SHOULDERS	
560.01	Method of Shoulder Construction - High Side of Superelevated Curve - Method I
DIVISION 8 - INCIDENTALS	
815.03	Pipe Underdrain and Blind Drain
840.72	Pipe Collar
876.02	Guide for Rip Rap at Pipe Outlets

STATE OF NORTH CAROLINA, DIVISION OF HIGHWAYS

CONVENTIONAL PLAN SHEET SYMBOLS

12/12/2016

BOUNDARIES AND PROPERTY:

State Line	-----
County Line	-----
Township Line	-----
City Line	-----
Reservation Line	-----
Property Line	-----
Existing Iron Pin	○
Computed Property Corner	-----
Property Monument	□
Parcel/Sequence Number	⑬
Existing Fence Line	-x-x-x-
Proposed Woven Wire Fence	○
Proposed Chain Link Fence	□
Proposed Barbed Wire Fence	◇
Existing Wetland Boundary	-----
Proposed Wetland Boundary	-----
Existing Endangered Animal Boundary	-----
Existing Endangered Plant Boundary	-----
Existing Historic Property Boundary	-----
Known Contamination Area: Soil	⊗-s-⊗
Potential Contamination Area: Soil	⊗-s-⊗
Known Contamination Area: Water	⊗-w-⊗
Potential Contamination Area: Water	⊗-w-⊗
Contaminated Site: Known or Potential	⊗?

BUILDINGS AND OTHER CULTURE:

Gas Pump Vent or U/G Tank Cap	○
Sign	○
Well	⊕
Small Mine	⊗
Foundation	□
Area Outline	□
Cemetery	⊕
Building	□
School	□
Church	⊕
Dam	▬

HYDROLOGY:

Stream or Body of Water	-----
Hydro, Pool or Reservoir	-----
Jurisdictional Stream	-----
Buffer Zone 1	-----
Buffer Zone 2	-----
Flow Arrow	←
Disappearing Stream	-----
Spring	○
Wetland	-----
Proposed Lateral, Tail, Head Ditch	-----
False Sump	-----

RAILROADS:

Standard Gauge	-----
RR Signal Milepost	-----
Switch	-----
RR Abandoned	-----
RR Dismantled	-----

RIGHT OF WAY & PROJECT CONTROL:

Secondary Horiz and Vert Control Point	◆
Primary Horiz Control Point	○
Primary Horiz and Vert Control Point	●
Exist Permanent Easement Pin and Cap	◇
New Permanent Easement Pin and Cap	◆
Vertical Benchmark	⊠
Existing Right of Way Marker	△
Existing Right of Way Line	-----
New Right of Way Line	-----
New Right of Way Line with Pin and Cap	-----
New Right of Way Line with Concrete or Granite R/W Marker	-----
New Control of Access Line with Concrete C/A Marker	-----
Existing Control of Access	-----
New Control of Access	-----
Existing Easement Line	-----
New Temporary Construction Easement	-----
New Temporary Drainage Easement	-----
New Permanent Drainage Easement	-----
New Permanent Drainage / Utility Easement	-----
New Permanent Utility Easement	-----
New Temporary Utility Easement	-----
New Aerial Utility Easement	-----

ROADS AND RELATED FEATURES:

Existing Edge of Pavement	-----
Existing Curb	-----
Proposed Slope Stakes Cut	-----
Proposed Slope Stakes Fill	-----
Proposed Curb Ramp	-----
Existing Metal Guardrail	-----
Proposed Guardrail	-----
Existing Cable Guiderail	-----
Proposed Cable Guiderail	-----
Equality Symbol	⊕
Pavement Removal	-----

VEGETATION:

Single Tree	⊗
Single Shrub	⊗

Note: Not to Scale *S.U.E. = Subsurface Utility Engineering

Hedge	-----
Woods Line	-----
Orchard	-----
Vineyard	-----

EXISTING STRUCTURES:

MAJOR: Bridge, Tunnel or Box Culvert	-----
Bridge Wing Wall, Head Wall and End Wall	-----
MINOR: Head and End Wall	-----
Pipe Culvert	-----
Footbridge	-----
Drainage Box: Catch Basin, DI or JB	-----
Paved Ditch Gutter	-----
Storm Sewer Manhole	-----
Storm Sewer	-----

UTILITIES:

POWER: Existing Power Pole	●
Proposed Power Pole	○
Existing Joint Use Pole	●
Proposed Joint Use Pole	○
Power Manhole	⊕
Power Line Tower	⊠
Power Transformer	⊠
U/G Power Cable Hand Hole	-----
H-Frame Pole	-----
U/G Power Line LOS B (S.U.E.*)	-----
U/G Power Line LOS C (S.U.E.*)	-----
U/G Power Line LOS D (S.U.E.*)	-----

TELEPHONE:

Existing Telephone Pole	●
Proposed Telephone Pole	○
Telephone Manhole	⊕
Telephone Pedestal	⊕
Telephone Cell Tower	⊕
U/G Telephone Cable Hand Hole	-----
U/G Telephone Cable LOS B (S.U.E.*)	-----
U/G Telephone Cable LOS C (S.U.E.*)	-----
U/G Telephone Cable LOS D (S.U.E.*)	-----
U/G Telephone Conduit LOS B (S.U.E.*)	-----
U/G Telephone Conduit LOS C (S.U.E.*)	-----
U/G Telephone Conduit LOS D (S.U.E.*)	-----
U/G Fiber Optics Cable LOS B (S.U.E.*)	-----
U/G Fiber Optics Cable LOS C (S.U.E.*)	-----
U/G Fiber Optics Cable LOS D (S.U.E.*)	-----

WATER:

Water Manhole	⊕
Water Meter	○
Water Valve	⊗
Water Hydrant	⊕
U/G Water Line LOS B (S.U.E.*)	-----
U/G Water Line LOS C (S.U.E.*)	-----
U/G Water Line LOS D (S.U.E.*)	-----
Above Ground Water Line	-----
TV: TV Pedestal	⊕
TV Tower	⊗
U/G TV Cable Hand Hole	-----
U/G TV Cable LOS B (S.U.E.*)	-----
U/G TV Cable LOS C (S.U.E.*)	-----
U/G TV Cable LOS D (S.U.E.*)	-----
U/G Fiber Optic Cable LOS B (S.U.E.*)	-----
U/G Fiber Optic Cable LOS C (S.U.E.*)	-----
U/G Fiber Optic Cable LOS D (S.U.E.*)	-----

GAS:

Gas Valve	◇
Gas Meter	⊕
U/G Gas Line LOS B (S.U.E.*)	-----
U/G Gas Line LOS C (S.U.E.*)	-----
U/G Gas Line LOS D (S.U.E.*)	-----
Above Ground Gas Line	-----

SANITARY SEWER:

Sanitary Sewer Manhole	⊕
Sanitary Sewer Cleanout	⊕
U/G Sanitary Sewer Line	-----
Above Ground Sanitary Sewer	-----
SS Forced Main Line LOS B (S.U.E.*)	-----
SS Forced Main Line LOS C (S.U.E.*)	-----
SS Forced Main Line LOS D (S.U.E.*)	-----

MISCELLANEOUS:

Utility Pole	●
Utility Pole with Base	□
Utility Located Object	○
Utility Traffic Signal Box	⊕
Utility Unknown U/G Line LOS B (S.U.E.*)	-----
U/G Tank; Water, Gas, Oil	-----
Underground Storage Tank, Approx. Loc.	-----
A/G Tank; Water, Gas, Oil	-----
Geoenvironmental Boring	⊕
U/G Test Hole LOS A (S.U.E.*)	-----
Abandoned According to Utility Records	AATUR
End of Information	E.O.I.

SURVEY CONTROL SHEET

STATE	STATE PROJECT REFERENCE NO.	SHEET NO.	TOTAL SHEETS
N.C.	W-5601EE	1C-1	

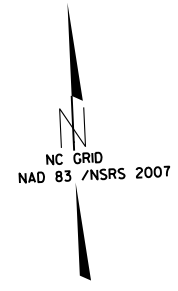

DATUM DESCRIPTION

THE LOCALIZED COORDINATE SYSTEM DEVELOPED FOR THIS PROJECT IS BASED ON THE STATE PLANE COORDINATES ESTABLISHED BY NCDOT FOR MONUMENT "GPS1"

WITH NAD 83/NSRS 2007 STATE PLANE GRID COORDINATES OF
 NORTHING: 671405.887(±) EASTING: 2086288.468(±)
 ELEVATION: 378.933(±)

THE AVERAGE COMBINED GRID FACTOR USED ON THIS PROJECT (GROUND TO GRID) IS: NONE

THE N.C. LAMBERT GRID BEARING AND LOCALIZED HORIZONTAL GROUND DISTANCE FROM "GPS1" TO -L- STATION IS

ALL LINEAR DIMENSIONS ARE LOCALIZED HORIZONTAL DISTANCES
 VERTICAL DATUM USED IS NAVD 88

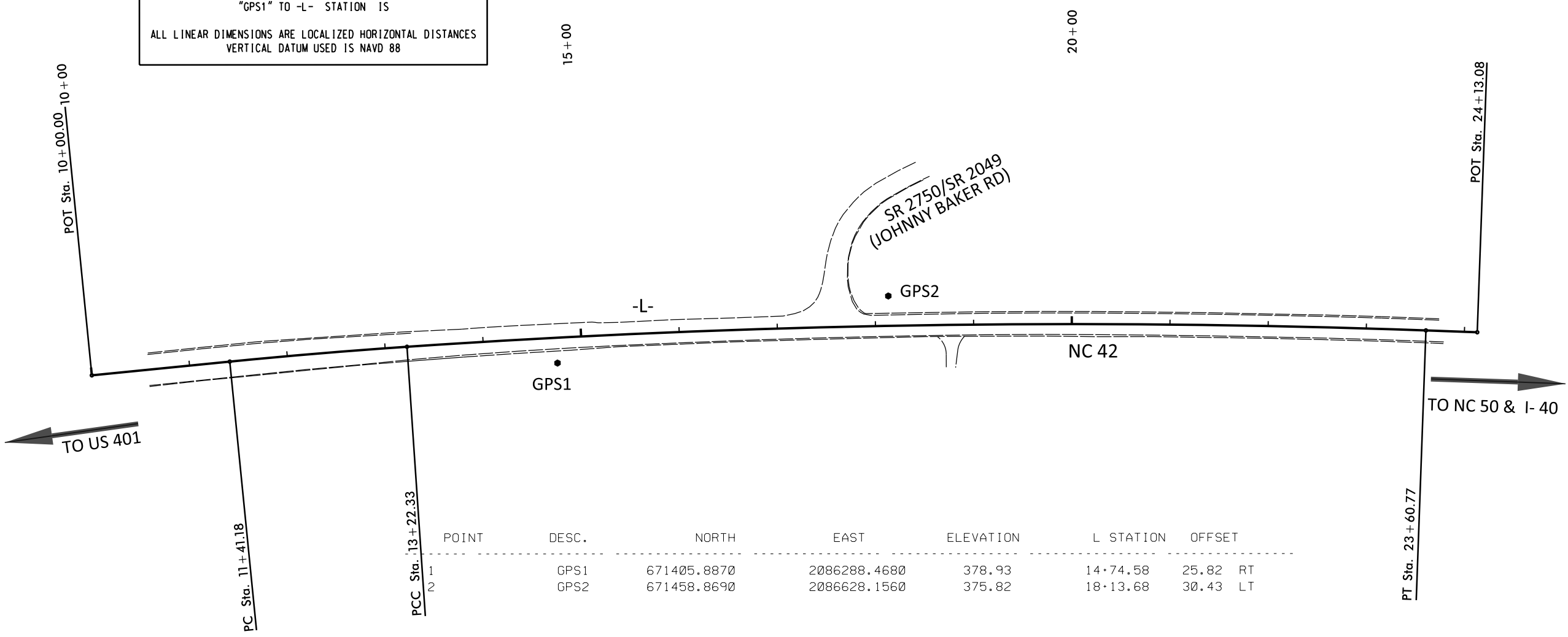

POINT	DESC.	NORTH	EAST	ELEVATION	L STATION	OFFSET
1	GPS1	671405.8870	2086288.4680	378.93	14+74.58	25.82 RT
2	GPS2	671458.8690	2086628.1560	375.82	18+13.68	30.43 LT

NOTE: DRAWING NOT TO SCALE

6/22/19

PROJECT REFERENCE NO. Doc 15601E	SHEET NO. 2A-1
ROADWAY DESIGN ENGINEER <i>Benjamin</i>	PAVEMENT DESIGN ENGINEER
Professional Seal SEAL 030459 ENGINEER BENJAMIN 6/22/2017	
DOCUMENT NOT CONSIDERED FINAL UNLESS ALL SIGNATURES COMPLETED	

PAVEMENT SCHEDULE	
C1	PROP. APPROX. 2" ASPHALT CONC. SURFACE COURSE, TYPE S9.5B, AT AN AVERAGE RATE OF 224 LBS. PER SQ. YD.
E1	PROP. APPROX. 11" ASPHALT CONC. BASE COURSE, TYPE B25.0B, AT AN AVERAGE RATE OF 627 LBS. PER SQ. YD. IN EACH OF TWO LAYERS.
T	EARTH MATERIAL.
U	EXISTING PAVEMENT.
V	2" MILLING.

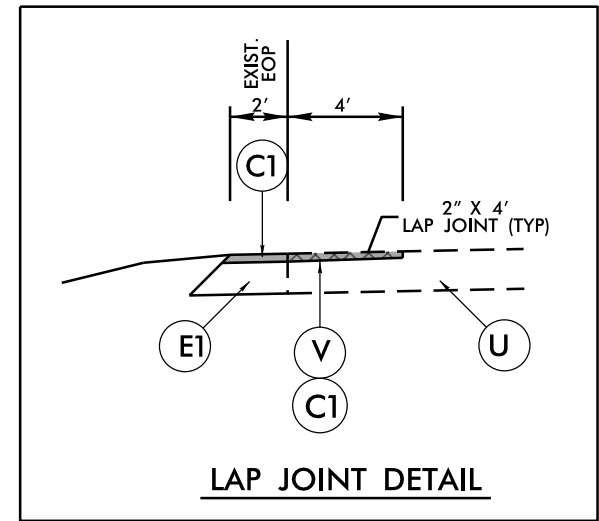

NOTES:
 1). THE PORTION OF EACH EXISTING PAVED SHOULDER THAT IS NOT FULL DEPTH IS TO BE REMOVED AND PAVED TO FULL DEPTH.
 2). PAVEMENT EDGE SLOPES ARE 1:1 UNLESS SHOWN OTHERWISE.

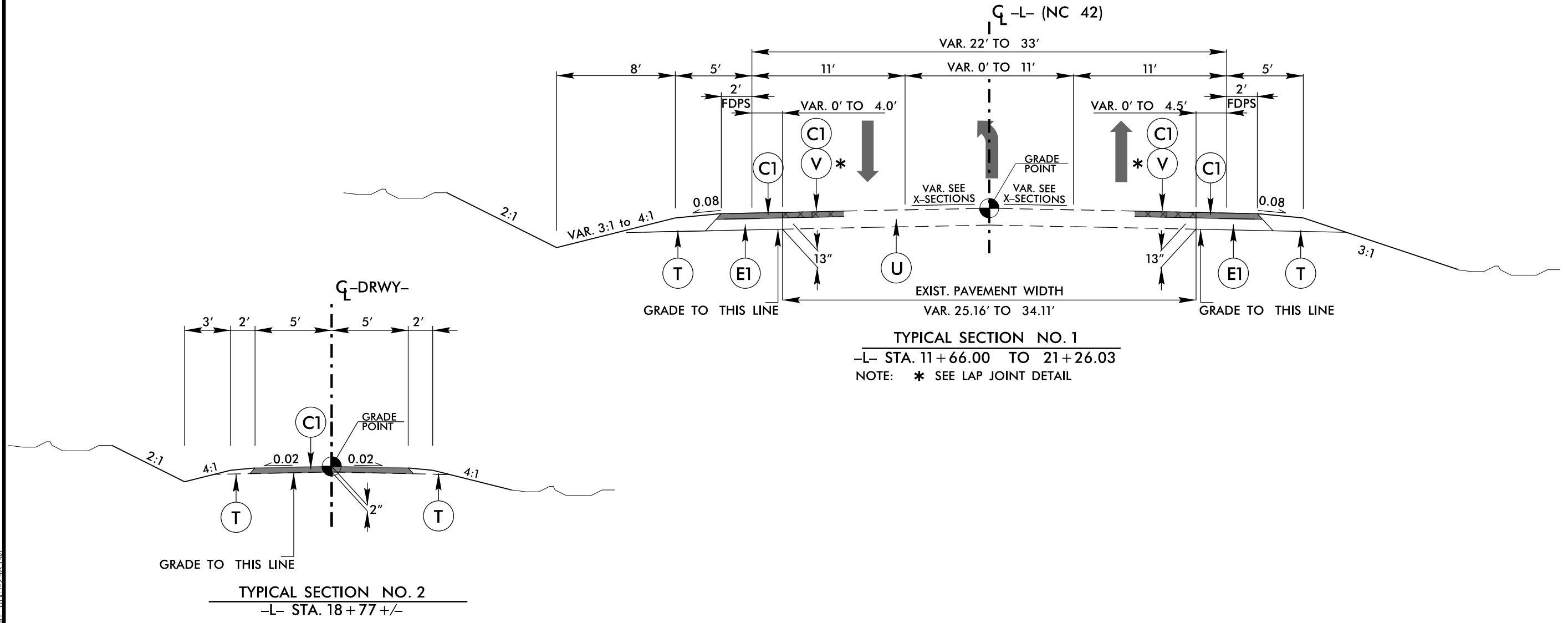

23-JUN-2017 12:55 R:\Roadway\Projects\15601E_Rdy-Typ_SHT2A.dgn

8/17/99

PROJECT REFERENCE NO.	SHEET NO.
W-5601EE	5
RW SHEET NO.	
ROADWAY DESIGN ENGINEER	HYDRAULICS ENGINEER
5/17/2017	
Designed by: Ben J. Royster	
DOCUMENT NOT CONSIDERED FINAL UNLESS ALL SIGNATURES COMPLETED	
SEE SHEET 6 FOR -L- PROFILE	

-L-
 PI Sta 18+42.02
 $\Delta = 5^{\circ} 56' 59.4''$ (RT)
 $D = 0^{\circ} 34' 22.6''$
 $L = 1,038.44'$
 $T = 519.69'$
 $R = 10,000.00'$

DAUBEN-SPECK,
 MARY
 JOY
 DB 15016
 PG 1312

BAKER, J ROYSTER
 DB 2942 PG 403

END T.I.P. PROJECT
 W-5601EE
 -L- STA. 21+26.03

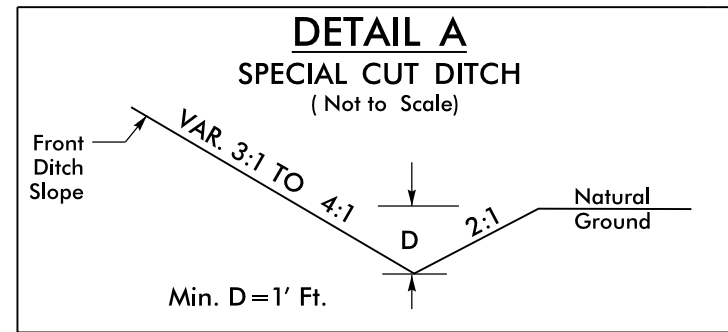
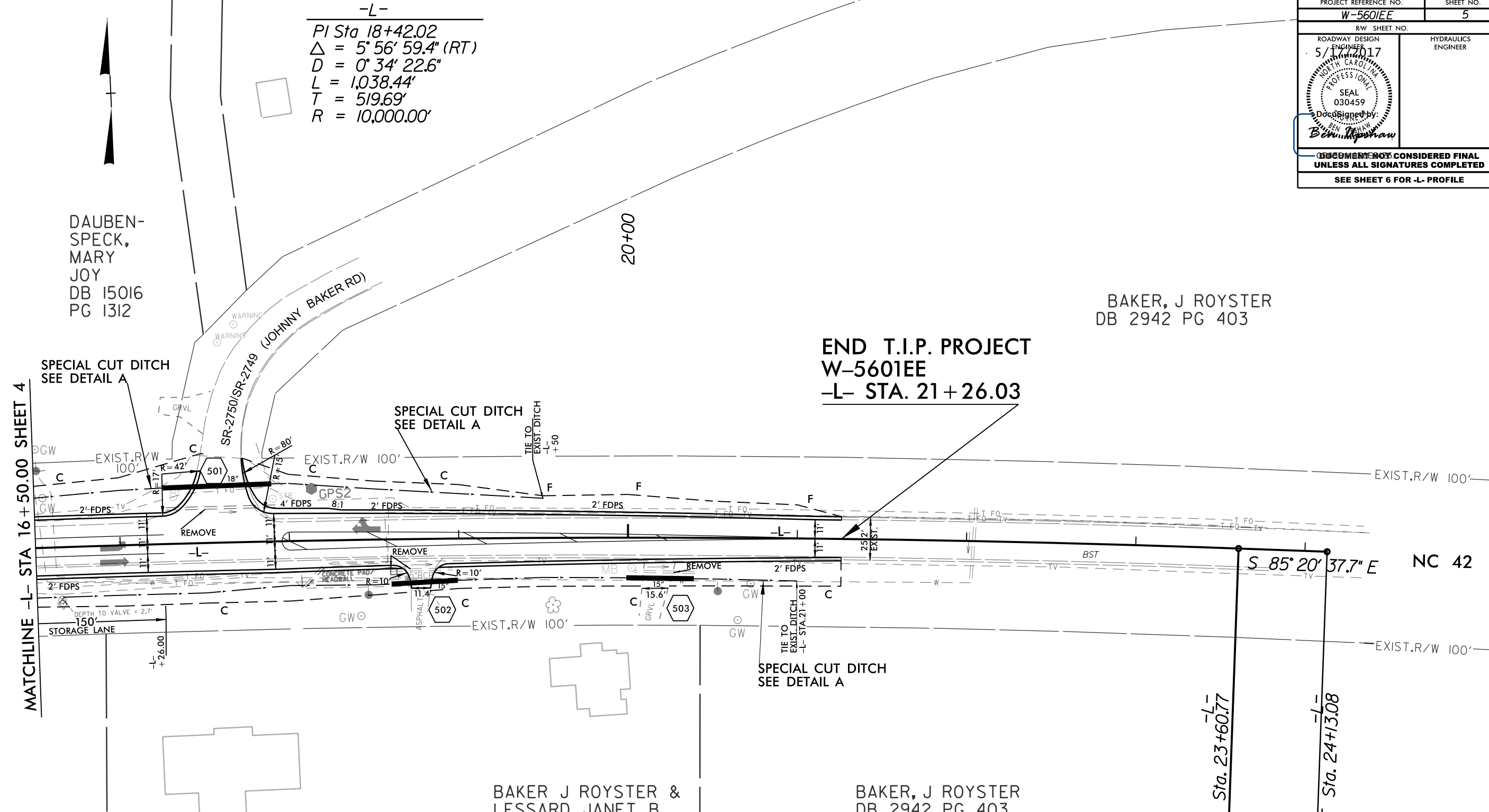

-L- FROM STA.16+25.00 TO STA.19+50.00 LT
 -L- FROM STA.15+50.00 TO STA.21+00.00 RT

I5-MAY-2017 17:07
 P:\Roadway\pco\W5601EE_Rdy_psh_05.dgn
 icbarova AT DWG-25R339

BEGIN T.I.P. PROJECT
W-5601EE
-L- STA. 11+66.00

-L- (NC 42)

END T.I.P. PROJECT
W-5601EE
-L- STA. 21+26.03

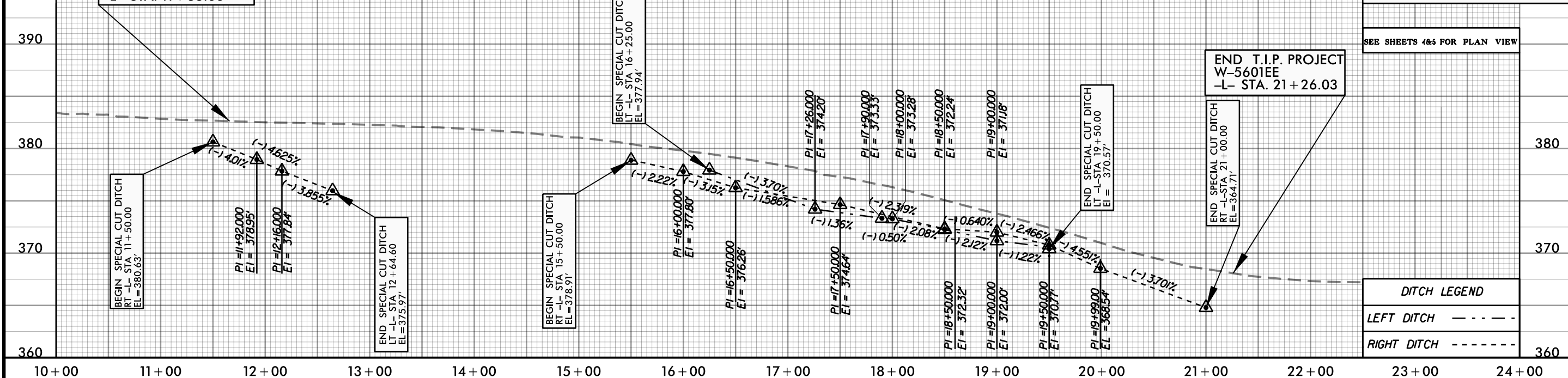

SEE SHEETS 4&5 FOR PLAN VIEW

DITCH LEGEND	
LEFT DITCH	-----
RIGHT DITCH	-----

LEGEND

GENERAL

- DIRECTION OF TRAFFIC FLOW
- DIRECTION OF PEDESTRIAN TRAFFIC FLOW
- EXIST. PVMT.
- NORTH ARROW
- PROPOSED PVMT.
- TEMP. SHORING (LOCATION PURPOSES ONLY)

- WORK AREA
- REMOVAL

SIGNALS

- EXISTING
- PROPOSED
- TEMPORARY

PAVEMENT MARKINGS

- EXISTING LINES
- TEMPORARY LINES

TRAFFIC CONTROL DEVICES

- BARRICADE (TYPE III)
- CONE
- DRUM SKINNY DRUM TUBULAR MARKER
- TEMPORARY CRASH CUSHION
- FLASHING ARROW BOARD
- FLAGGER
- LAW ENFORCEMENT
- TRUCK MOUNTED ATTENUATOR (TMA)
- CHANGEABLE MESSAGE SIGN

TEMPORARY SIGNING

- PORTABLE SIGN
- STATIONARY SIGN
- STATIONARY OR PORTABLE SIGN

PAVEMENT MARKERS

- CRYSTAL/CRYSTAL
- CRYSTAL/RED
- YELLOW/YELLOW

PAVEMENT MARKING SYMBOLS

- PAVEMENT MARKING SYMBOLS

ROADWAY STANDARD DRAWINGS

REV. SEPTEMBER 2011

THE FOLLOWING ROADWAY STANDARDS AS APPEAR IN "ROADWAY STANDARD DRAWINGS" - PROJECT SERVICES UNIT - N.C. DEPARTMENT OF TRANSPORTATION - RALEIGH, N.C., DATED JANUARY 2012 ARE APPLICABLE TO THIS PROJECT AND BY REFERENCE HEREBY ARE CONSIDERED A PART OF THESE PLANS:

STD.NO.	TITLE
1101.01	WORK ZONE ADVANCE WARNING SIGNS
1101.02	TEMPORARY LANE CLOSURES
1101.04	TEMPORARY SHOULDER CLOSURES
1101.05	WORK ZONE VEHICLE ACCESSES
1101.11	TRAFFIC CONTROL DESIGN TABLES
1110.01	STATIONARY WORK ZONE SIGNS
1110.02	PORTABLE WORK ZONE SIGNS
1130.01	DRUM
1135.01	CONES
1150.01	FLAGGING DEVICES
1180.01	SKINNY-DRUM
1205.01	PAVEMENT MARKINGS - LINE TYPES & OFFSETS
1205.02	PAVEMENT MARKINGS - 2 LANE & MULTILANE ROADWAYS
1205.04	PAVEMENT MARKINGS - INTERSECTIONS
1205.05	PAVEMENT MARKINGS - TURN LANES
1250.08	PAVEMENT MARKINGS - SYMBOLS AND WORD MESSAGES
1250.09	PAVEMENT MARKINGS - PAINTED ISLANDS

GENERAL NOTES

CHANGES MAY BE REQUIRED WHEN PHYSICAL DIMENSIONS IN THE DETAIL DRAWINGS, STANDARD DETAILS, AND ROADWAY DETAILS ARE NOT ATTAINABLE TO MEET FIELD CONDITIONS OR RESULT IN DUPLICATE OR UNDESIRABLE OVERLAPPING OF DEVICES. MODIFICATION MAY INCLUDE: MOVING, SUPPLEMENTING, COVERING, OR REMOVAL OF DEVICES AS DIRECTED BY THE ENGINEER.

THE FOLLOWING GENERAL NOTES APPLY AT ALL TIMES FOR THE DURATION OF THE CONSTRUCTION PROJECT EXCEPT WHEN OTHERWISE NOTED IN THE PLAN OR DIRECTED BY THE ENGINEER.

TIME RESTRICTIONS

- A) DO NOT CLOSE OR NARROW TRAVEL LANES AS FOLLOWS:

ROAD NAME	DAY AND TIME RESTRICTIONS
ALL ROADS	MONDAY THRU FRIDAY 6 AM TO 9 AM & 4 PM TO 7 PM

- B) REMOVE LANE CLOSURE DEVICES FROM THE LANE WHEN WORK IS NOT BEING PERFORMED BEHIND THE LANE CLOSURE OR WHEN A LANE CLOSURE IS NO LONGER NEEDED OR AS DIRECTED BY THE ENGINEER.
- C) WHEN PERSONNEL AND/OR EQUIPMENT ARE WORKING WITHIN 15 FT OF AN OPEN TRAVEL LANE, CLOSE THE NEAREST OPEN SHOULDER USING ROADWAY STANDARD DRAWING NO. 1101.04 UNLESS THE WORK AREA IS PROTECTED BY BARRIER OR GUARDRAIL OR A LANE CLOSURE IS INSTALLED.
- D) WHEN PERSONNEL AND/OR EQUIPMENT ARE WORKING ON THE SHOULDER ADJACENT TO AN UNDIVIDED FACILITY AND WITHIN 5 FT OF AN OPEN TRAVEL LANE, CLOSE THE NEAREST OPEN TRAVEL LANE USING ROADWAY STANDARD DRAWING NO. 1101.02 UNLESS THE WORK AREA IS PROTECTED BY BARRIER OR GUARDRAIL.

WHEN PERSONNEL AND/OR EQUIPMENT ARE WORKING ON THE SHOULDER ADJACENT TO A DIVIDED FACILITY AND WITHIN 10 FT OF AN OPEN TRAVEL LANE, CLOSE THE NEAREST OPEN TRAVEL LANE USING ROADWAY STANDARD DRAWING NO. 1101.02 UNLESS THE WORK AREA IS PROTECTED BY BARRIER OR GUARDRAIL.

- E) WHEN PERSONNEL AND/OR EQUIPMENT ARE WORKING WITHIN A LANE OF TRAVEL OF AN UNDIVIDED OR DIVIDED FACILITY, CLOSE THE LANE ACCORDING TO THE TRAFFIC CONTROL PLANS, ROADWAY STANDARD DRAWINGS, OR AS DIRECTED BY THE ENGINEER. CONDUCT THE WORK SO THAT ALL PERSONNEL AND/OR EQUIPMENT REMAIN WITHIN THE CLOSED TRAVEL LANE.
- F) DO NOT WORK SIMULTANEOUSLY WITHIN 15 FT ON BOTH SIDES OF AN OPEN TRAVELWAY, RAMP, OR LOOP WITHIN THE SAME LOCATION UNLESS PROTECTED WITH GUARDRAIL OR BARRIER.
- G) PROVIDE TRAFFIC CONTROL FOR APPROPRIATE LANE CLOSURES FOR SURVEYING DONE BY THE DEPARTMENT.

PAVEMENT EDGE DROP OFF REQUIREMENTS

- H) BACKFILL AT A 6:1 SLOPE UP TO THE EDGE AND ELEVATION OF EXISTING PAVEMENT IN AREAS ADJACENT TO AN OPENED TRAVEL LANE THAT HAS AN EDGE OF PAVEMENT DROP-OFF AS FOLLOWS:

BACKFILL DROP-OFFS THAT EXCEED 2 INCHES ON ROADWAYS WITH POSTED SPEED LIMITS OF 45 MPH OR GREATER.

BACKFILL DROP-OFFS THAT EXCEED 3 INCHES ON ROADWAYS WITH POSTED SPEED LIMITS LESS THAN 45 MPH.

BACKFILL WITH SUITABLE COMPACTED MATERIAL, AS APPROVED BY THE ENGINEER, AT NO EXPENSE TO THE DEPARTMENT.

- I) DO NOT EXCEED A DIFFERENCE OF 2 INCHES IN ELEVATION BETWEEN OPEN LANES OF TRAFFIC FOR NOMINAL LIFTS OF 1.5 INCHES. INSTALL ADVANCE WARNING "UNEVEN LANES" SIGNS (W8-11) 50FT IN ADVANCE AND A MINIMUM OF EVERY HALF MILE THROUGHOUT THE UNEVEN AR

TRAFFIC PATTERN ALTERATIONS

- J) NOTIFY THE ENGINEER THIRTY (30) CALENDAR DAYS PRIOR TO ANY TRAFFIC PATTERN ALTERATION.

SIGNING

- K) INSTALL ADVANCE WORK ZONE WARNING SIGNS WHEN WORK IS WITHIN 40 FT FROM THE EDGE OF TRAVEL LANE AND NO MORE THAN THREE (3) DAYS PRIOR TO THE BEGINNING OF CONSTRUCTION.
- L) ENSURE ALL NECESSARY SIGNING IS IN PLACE PRIOR TO ALTERING ANY TRAFFIC PATTERN.

TRAFFIC CONTROL DEVICES

- M) WHEN LANE CLOSURES ARE NOT IN EFFECT SPACE CHANNELIZING DEVICES IN WORK AREAS NO GREATER IN FEET THAN TWICE THE POSTED SPEED LIMIT (MPH) EXCEPT, 10 FT ON-CENTER IN RADII, AND 3 FT OFF THE EDGE OF AN OPEN TRAVELWAY. REFER TO STANDARD SPECIFICATIONS FOR ROADS AND STRUCTURES SECTIONS 1130 (DRUMS), 1135 (CONES) AND 1180 (SKINNY DRUMS) FOR ADDITIONAL REQUIREMENTS.

PAVEMENT MARKINGS AND MARKERS

- N) INSTALL TEMPORARY PAVEMENT MARKINGS AND TEMPORARY PAVEMENT MARKERS ON INTERIM LAYERS OF PAVEMENT AS FOLLOWS:
- | ROAD NAME | MARKING | MARKER |
|-----------|---------|--------|
| ALL ROADS | PAINT | NONE |
- O) TIE PROPOSED PAVEMENT MARKING LINES TO EXISTING PAVEMENT MARKING LINES.
- P) REMOVE/REPLACE ANY CONFLICTING/DAMAGED PAVEMENT MARKINGS AND MARKERS BY THE END OF EACH DAY'S OPERATION.

DOCUMENT NOT CONSIDERED FINAL UNLESS ALL SIGNATURES COMPLETED

APPROVED: *Ben Upshaw*
DATE: 5/26/2017

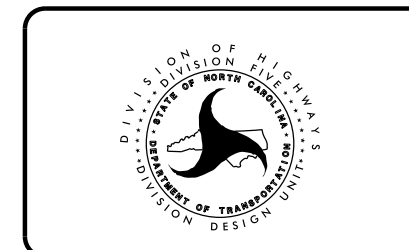

STATE OF NORTH CAROLINA
DIVISION OF HIGHWAYS

SIGNING & PAVEMENT MARKING PLAN
WAKE COUNTY

LOCATION: NC 42 AT SR 2750/SR 2749 (JOHNNY BAKER RD)

INDEX

SHEET NO.	DESCRIPTION
PMP-1	PAVEMENT MARKING PLAN COVER SHEET, SCHEDULE, NOTES, AND STANDARD DRAWINGS
PMP-2 THRU PMP-3	PAVEMENT MARKING PLANS

PAVEMENT MARKING SCHEDULE

SYMBOL	DESCRIPTION
<u>THERMOPLASTIC(4", 90 MILS)</u>	
TA	WHITE EDGELINE LINE
<u>THERMOPLASTIC(4", 120 MILS)</u>	
T8	2 FT. - 6 FT. WHITE MIN SKP LINE
TD	3 FT. - 9 FT. WHITE MIN SKP LINE
TE	WHITE SOLID LANE LINE
TI	YELLOW DOUBLE CENTER LINE
<u>THERMOPLASTIC(12", 90 MILS)</u>	
TV	YELLOW DIAGONAL LINE
<u>THERMOPLASTIC(24", 120 MILS)</u>	
T2	WHITE STOPBAR LINE
<u>THERMOPLASTIC PAVEMENT MARKING SYMBOLS (90 MILS)</u>	
UA	LEFT TURN ARROW
UC	STRAIGHT ARROW
<u>MARKERS</u>	
SNOWPLOWABLE RAISED PAVEMENT MARKERS	
ME	YELLOW & YELLOW
MF	CRYSTAL & RED

**GENERAL NOTES
PAVEMENT MARKING**

- THE FOLLOWING GENERAL NOTES APPLY AT ALL TIMES FOR THE DURATION OF THE CONSTRUCTION PROJECT, EXCEPT WHEN OTHERWISE NOTED IN THE PLAN, OR DIRECTED BY THE ENGINEER.
- A) INSTALL PAVEMENT MARKINGS AND PAVEMENT MARKERS ON THE FINAL SURFACE AS FOLLOWS:
- | ROAD NAME | MARKING | MARKER |
|-----------|---------------|--------------|
| ALL ROADS | THERMOPLASTIC | SNOWPLOWABLE |
- B) TIE PROPOSED PAVEMENT MARKING LINES TO EXISTING PAVEMENT MARKING LINES.
C) REMOVE/REPLACE ANY CONFLICTING/DAMAGED PAVEMENT MARKINGS AND MARKERS.
D) UNLESS OTHERWISE SPECIFIED, HEATED-IN-PLACE THERMOPLASTIC MAY BE USED IN LIEU OF EXTRUDED THERMOPLASTIC FOR STOP BARS, SYMBOLS, CHARACTERS AND DIAGONALS. IF HEATED-IN-PLACE IS USED, IT SHALL BE PAID FOR USING THE EXTRUDED THERMOPLASTIC PAY ITEM.

**GENERAL NOTES
SIGNING**

- A) SIGNS FURNISHED BY THE STATE.
B) WHEN NOT STATIONED OR DIMENSIONED ON PLANS, ALL 'E' AND 'F' SIGNS SHALL BE FIELD LOCATED BY THE ENGINEER.
C) WHEN EXISTING SIGNS ARE REMOVED AND INSTALLED ON NEW SUPPORTS, THE RE-ERECTION SHALL IMMEDIATELY FOLLOW THE REMOVAL.
D) ALL EXISTING SIGNS ON "U" CHANNEL POST WITHIN THE PROJECT LIMITS SHALL BE REMOVED AND DISPOSED OF UNLESS OTHERWISE NOTED ON PLANS.
E) THE BACKGROUND FOR TYPE E & F SIGNS SHALL BE TYPE C REFLECTIVE SHEETING.

ROADWAY STANDARD DRAWINGS

THE FOLLOWING ROADWAY STANDARDS AS APPEAR IN "ROADWAY STANDARD DRAWINGS" - PROJECT SERVICES UNIT - N.C. DEPARTMENT OF TRANSPORTATION - RALEIGH, N.C., DATED JANUARY 2012 ARE APPLICABLE TO THIS PROJECT AND BY REFERENCE HEREBY ARE CONSIDERED A PART OF THESE PLANS:

STD. NO.	TITLE
1205.01	PAVEMENT MARKINGS - LINE TYPES & OFFSETS
1205.02	PAVEMENT MARKINGS - 2 LANE & MULTILANE ROADWAYS
1205.04	PAVEMENT MARKINGS - INTERSECTION
1205.05	PAVEMENT MARKINGS - TURN LANES
1205.08	PAVEMENT MARKINGS - SYMBOLS & WORD MESSAGES
1205.09	PAVEMENT MARKINGS - PAINTED ISLANDS
1250.01	RAISED PAVEMENT MARKERS - INSTALLATION SPACING
1253.01	SNOWPLOWABLE RAISED PAVEMENT MARKERS

DocuSigned by:

APPROVED: *Ben Upshaw*
DATE: 5/17/2017

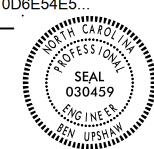

DOCUMENT NOT CONSIDERED FINAL
UNLESS ALL SIGNATURES COMPLETED

-L-

PI Sta 12+31.76	PI Sta 18+42.02
$\Delta = 1^{\circ} 47' 22.3" (RT)$	$\Delta = 5^{\circ} 56' 59.4" (RT)$
$D = 0^{\circ} 59' 16.3"$	$D = 0^{\circ} 34' 22.6"$
$L = 181.15'$	$L = 1,038.44'$
$T = 90.58'$	$T = 519.69'$
$R = 5,800.00'$	$R = 10,000.00'$

10+00

15+00

BEGIN T.I.P. PROJECT
W-5601EE
-L- STA. 11+66.00

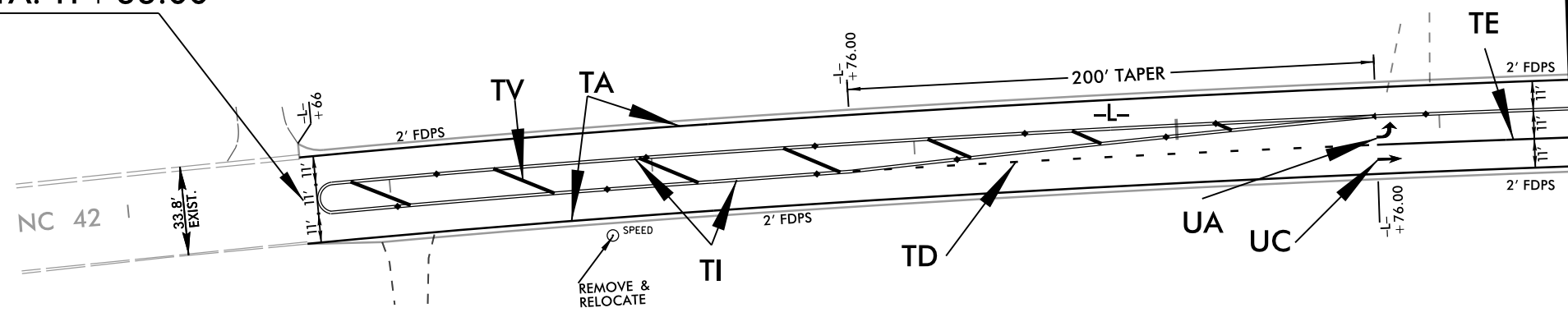

MATCHLINE -L- STA 16+50.00 SHEET PMP-3

THERMOPLASTIC PAVEMENT MARKING LEGEND	
ⓐ SOLID WHITE EDGE LINE	ⓐ SOLID WHITE LANE LINE
ⓓ 3FT - 9FT WHITE MIN SKP LINE	ⓐ SOLID DBL YELLOW CENTER LINE
Ⓥ SOLID YELLOW DIAGONALS LINE	ⓐ LEFT TURN ARROW
	ⓐ STRAIGHT ARROW

DocuSigned by:
Ben Upshaw

APPROVED: _____
DATE: 5/17/2017

CD6EB110D6E54E5...

SEAL
030459
ENGINEER
BEN UPSHAW

DOCUMENT NOT CONSIDERED FINAL
UNLESS ALL SIGNATURES COMPLETED

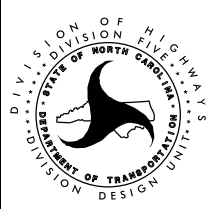

8/17/99
15-MAY-2017 11:42
R:\Roadway\Projects\W-5601EE-Rdy-PM2.DGN
ST-DIVS-248300

-L-

PI Sta 12+31.76	PI Sta 18+42.02
$\Delta = 1^{\circ} 47' 22.3" (RT)$	$\Delta = 5^{\circ} 56' 59.4" (RT)$
$D = 0^{\circ} 59' 16.3"$	$D = 0^{\circ} 34' 22.6"$
$L = 181.15'$	$L = 1,038.44'$
$T = 90.58'$	$T = 519.69'$
$R = 5,800.00'$	$R = 10,000.00'$

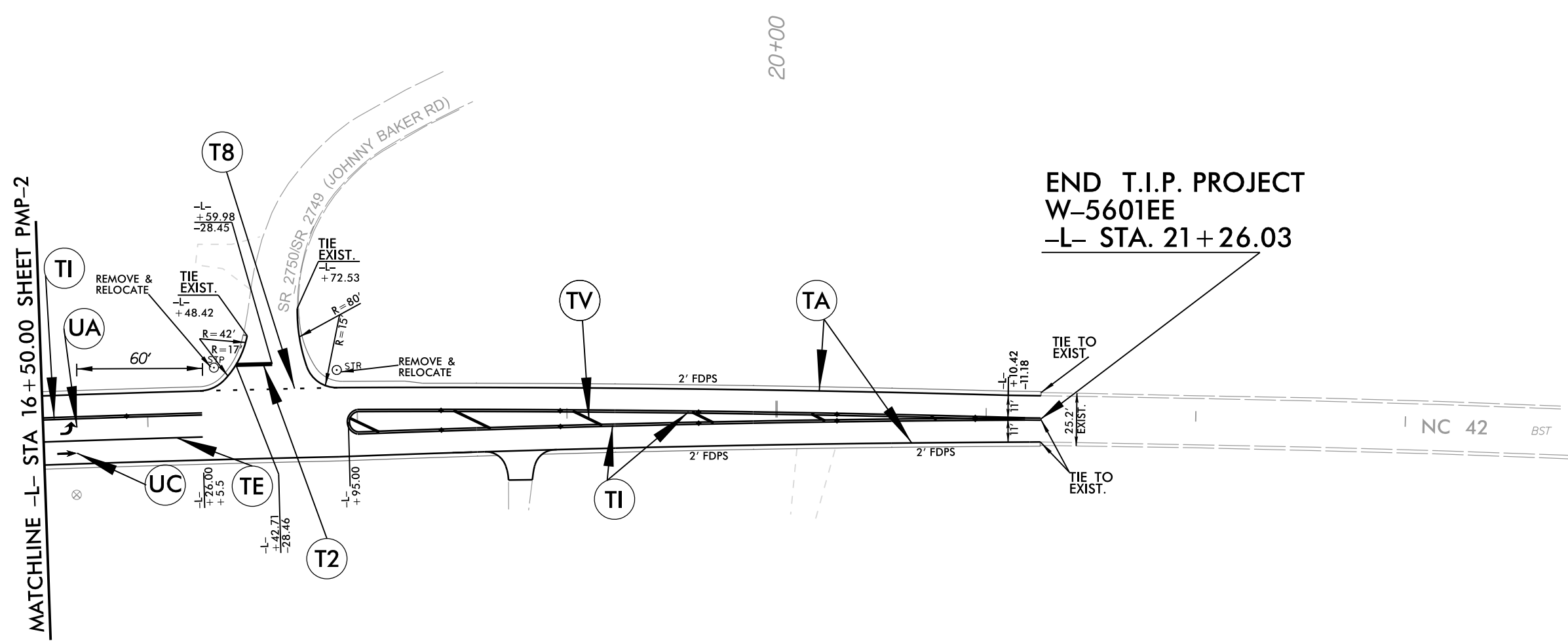

THERMOPLASTIC PAVEMENT MARKING LEGEND	
T2 SOLID WHITE STOP BAR LINE	TE SOLID WHITE LANE LINE
T8 2 FT. - 6 FT. WHITE MIN SKP LINE	TI SOLID DBL YELLOW CENTER LINE
TV SOLID YELLOW DIAGONALS LINE	UA ← LEFT TURN ARROW
TA SOLID WHITE EDGE LINE	UC ↑ STRAIGHT ARROW

DocuSigned by:
Ben Upshaw

APPROVED: *Ben Upshaw*
DATE: 5/17/2017

110D6E54E5

SEAL
030459
ENGINEER
BEN UPSHAW

DOCUMENT NOT CONSIDERED FINAL
UNLESS ALL SIGNATURES COMPLETED

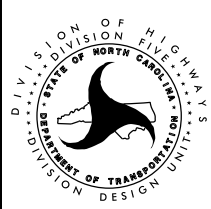

8/17/99
 16-MAY-2017 15:22 PMP-W5601EE-Rdy_PMS.DGN
 R:\Roadway\PC\AT\DIV5-288340

DIVISION OF HIGHWAYS
STATE OF NORTH CAROLINA

PROJECT REFERENCE NO.	SHEET NO.
W-560IEE	EC-3B
ROADWAY DESIGN ENGINEER	HYDRAULICS ENGINEER

SOIL STABILIZATION TIMEFRAMES

<i>SITE DESCRIPTION</i>	<i>STABILIZATION TIME</i>	<i>TIMEFRAME EXCEPTIONS</i>
PERIMETER DIKES, SWALES, DITCHES AND SLOPES	7 DAYS	NONE
HIGH QUALITY WATER (HQW) ZONES	7 DAYS	NONE
SLOPES STEEPER THAN 3:1	7 DAYS	IF SLOPES ARE 10' OR LESS IN LENGTH AND ARE NOT STEEPER THAN 2:1, 14 DAYS ARE ALLOWED.
SLOPES 3:1 OR FLATTER	14 DAYS	7 DAYS FOR SLOPES GREATER THAN 50' IN LENGTH.
ALL OTHER AREAS WITH SLOPES FLATTER THAN 4:1	14 DAYS	NONE, EXCEPT FOR PERIMETERS AND HQW ZONES.

8/17/99

-L-
 PI Sta 12+31.76 PI Sta 18+42.02
 $\Delta = 1^{\circ} 47' 22.3''$ (RT) $\Delta = 5^{\circ} 56' 59.4''$ (RT)
 $D = 0^{\circ} 59' 16.3''$ $D = 0^{\circ} 34' 22.6''$
 $L = 181.15'$ $L = 1,038.44'$
 $T = 90.58'$ $T = 519.69'$
 $R = 5,800.00'$ $R = 10,000.00'$

Std. #	Description	Symbol
1605.01	Temporary Silt Fence	
1606.01	Special Sediment Control Fence	▤ ▤ ▤ ▤ ▤ ▤ ▤ ▤ ▤ ▤
1622.01	Temporary Berms and Slope Drains	— T —
1630.02	Silt Basin Type B	▨
1630.03	Temporary Silt Ditch	— T —
1630.05	Temporary Diversion	— T —
1630.06	Special Stilling Basin	▭
1632.03	Rock Inlet Sediment Trap Type C	▣
1633.01	Temporary Rock Silt Check Type-A	▨
	Temporary Rock Silt Check Type-A with Matting and Polyacrylamide (PAM)	▨
1633.02	Temporary Rock Silt Check Type-B	▣
	Wattle	— T —
	Wattle with Polyacrylamide (PAM)	— T —
1634.02	Temporary Rock Sediment Dam Type-B	▣
1635.01	Rock Pipe Inlet Sediment Trap Type-A	▣

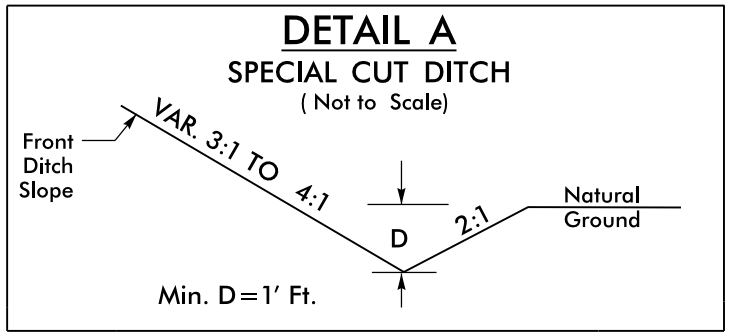
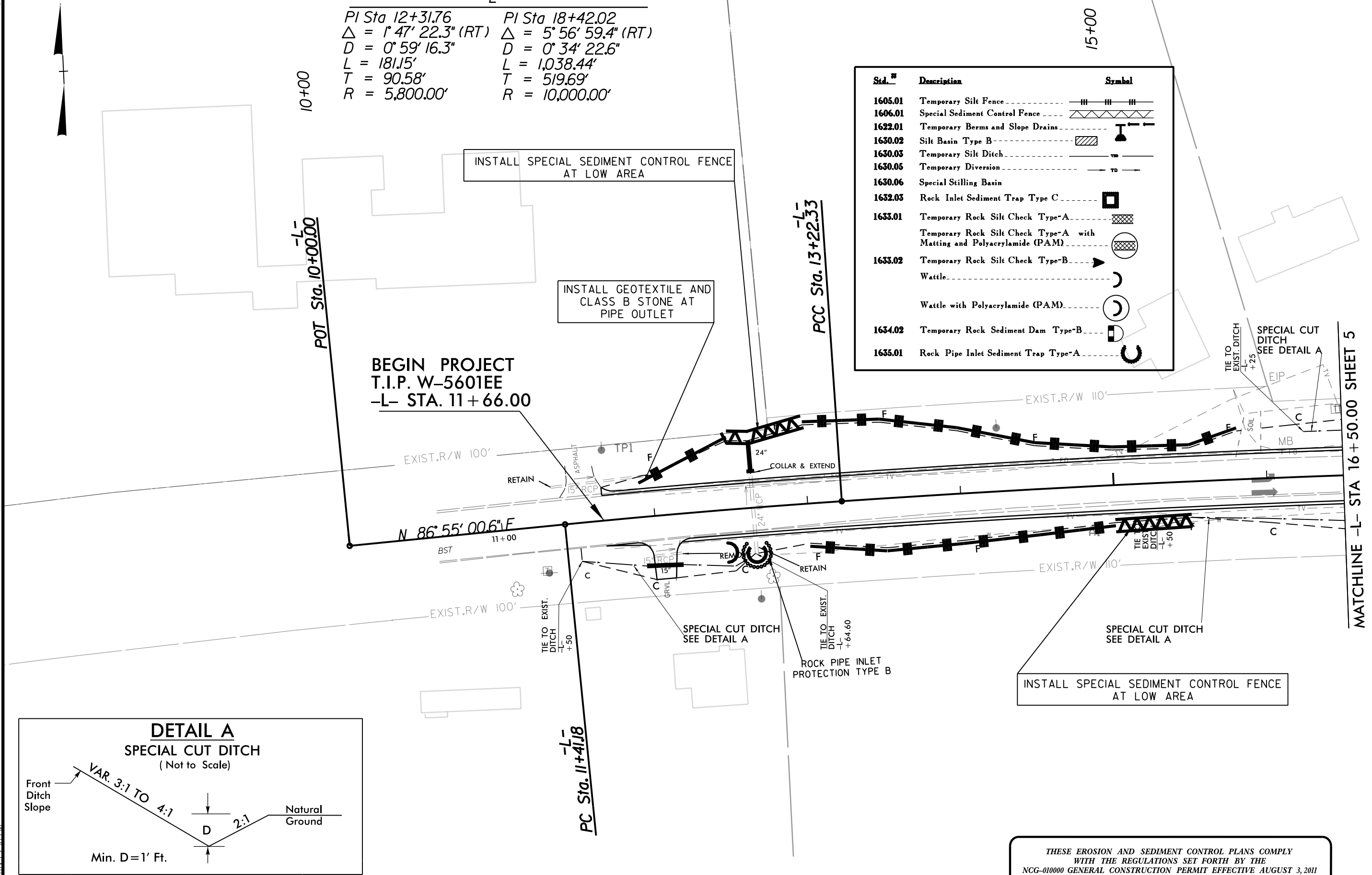

-L- FROM STA.16+25.00 TO STA.19+50.00 LT
 -L- FROM STA.11+50.00 TO STA.12+64.60 RT
 -L- FROM STA.15+50.00 TO STA.21+00.00 RT

THESE EROSION AND SEDIMENT CONTROL PLANS COMPLY WITH THE REGULATIONS SET FORTH BY THE NCG-010000 GENERAL CONSTRUCTION PERMIT EFFECTIVE AUGUST 3, 2011 ISSUED BY THE NORTH CAROLINA DEPARTMENT OF ENVIRONMENT AND NATURAL RESOURCES DIVISION OF WATER QUALITY.

15-MAY-2017 17:09 P:\Environment\15-Design\W5601EE_EC_dsn_psh_4.dgn

-L-
 PI Sta 18+42.02
 $\Delta = 5^{\circ} 56' 59.4''$ (RT)
 $D = 0^{\circ} 34' 22.6''$
 $L = 1,038.44'$
 $T = 519.69'$
 $R = 10,000.00'$

DAUBEN-
 SPECK,
 MARY
 JOY
 DB 15016
 PG 1312

BAKER, J ROYSTER
 DB 2942 PG 403

END T.I.P. PROJECT
 W-5601EE
 -L- STA. 21+26.03

MATCHLINE -L- STA 16+50.00 SHEET 4

SPECIAL CUT DITCH
 SEE DETAIL A

SPECIAL CUT DITCH
 SEE DETAIL A

SPECIAL CUT DITCH
 SEE DETAIL A

EXIST. R/W 100'

EXIST. R/W 100'

EXIST. R/W 100'

DEPTH TO VALVE = 2.7'

EXIST. R/W 100'

EXIST. R/W 100'

S 85° 20' 37.7" E

PT Sta. 23+60.77

POT Sta. 24+13.08

BAKER J ROYSTER &
 LESSARD, JANET B

BAKER, J ROYSTER
 DB 2942 PG 403

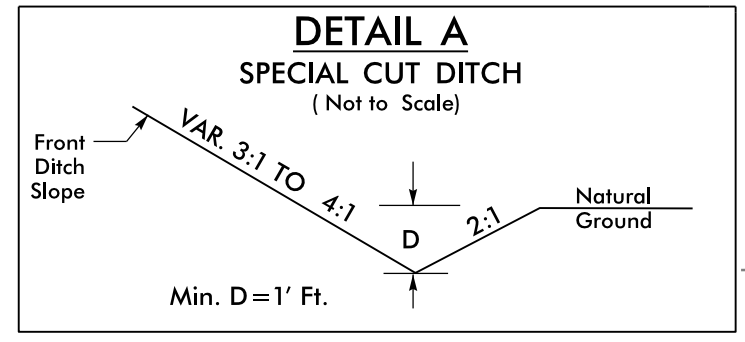

-L- FROM STA.16+25.00 TO STA.19+50.00 LT
 -L- FROM STA.15+50.00 TO STA.21+00.00 RT

15-MAY-2017 17:09
 R:\Environmental\Design\W5601EE.EC.dwg-psh-5.dgn
 jchase

8/17/99

